



Entratek GmbH
Liliencronstr. 65
21629 Neu Wulmstorf
info@entratek.de
+49 04030857066



INSTALLATION MANUAL INSTALLATIONSANLEITUNG

Universal EasySolar Bracket-UV

Universelle einfache Solarhalterung-UV

SC01-EUV033-KS

1. Installation tools

1. Werkzeuge für die Installation



Allen Key 6mm
(M8 Hexagon Socket Screw)
Inbusschlüssel 6mm
(M8 Innensechskantschraube)



Tape
Meßband



13mm Spanner
13mm Maulschlüssel

2. Packaging and details

2. Verpackung und Details

(Accessories are subject to the actual product)
(Zubehör unterliegt dem tatsächlichen Produkt)

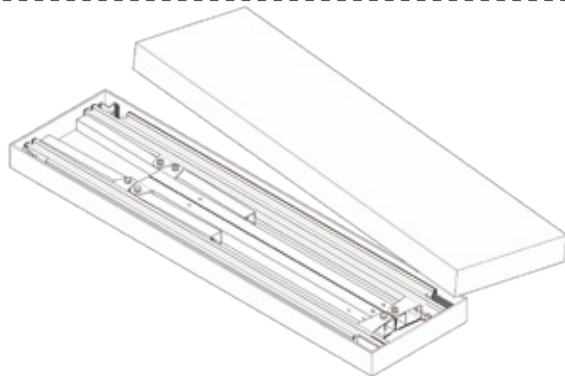

☑ x 2

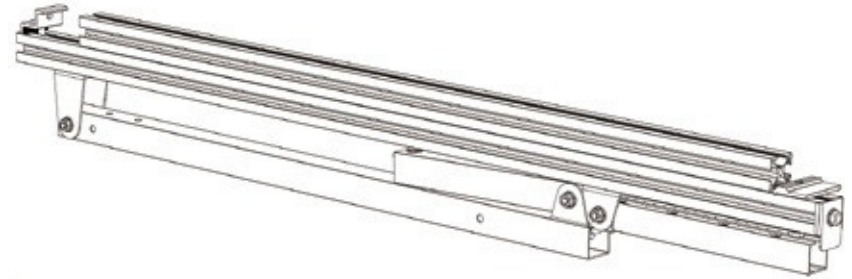

Two sets of tripods.
Zwei Sätze Stative.

☑ x 2

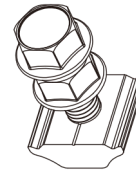

Bolt for Inverter
Schrauben für
Wechselrichter

☑ x 2

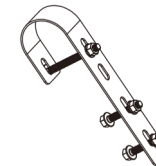

Hooks
Haken

☑ x 2

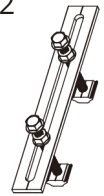

Bottom fasteners
Unterer Verschluss

☑ x 4

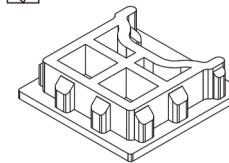

End Cap 0047
Endkappe 0047

☑ x 2

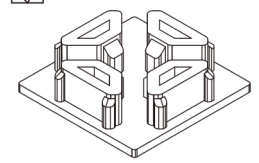

End Cap 0048
Endkappe 0048

3.Installation Instruction

3.Installationsanweisung

3.1 Take the tripod out and unfold it

3.1 Nehmen Sie das Stativ heraus und klappen Sie es auf

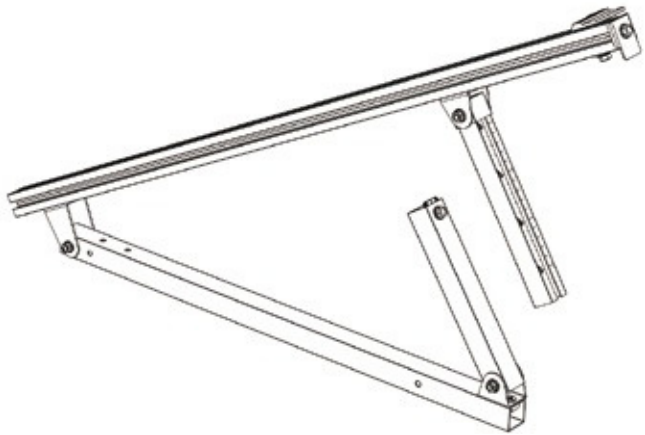

3.2 Rotating the tripod and insert one end of the column with scale marks (L026) into the other square tube (L025)

3.2 Drehbares Stativ, Stecken Sie das eine Ende der Säule mit den Skalenmarkierungen (L026) in das andere Vierkantrohr (L025)

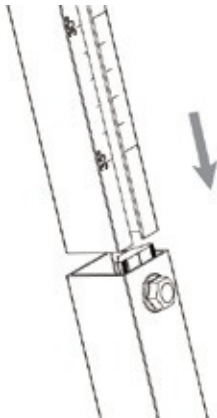

3.3 Align the scale by adjusting the insertion depth of L026, adjust the angle, and lock it

3.3 Richten Sie die Skala durch Einstellen der Einstecktiefe von L026 aus, stellen Sie den Winkel des Dreieckes ein und verriegeln.

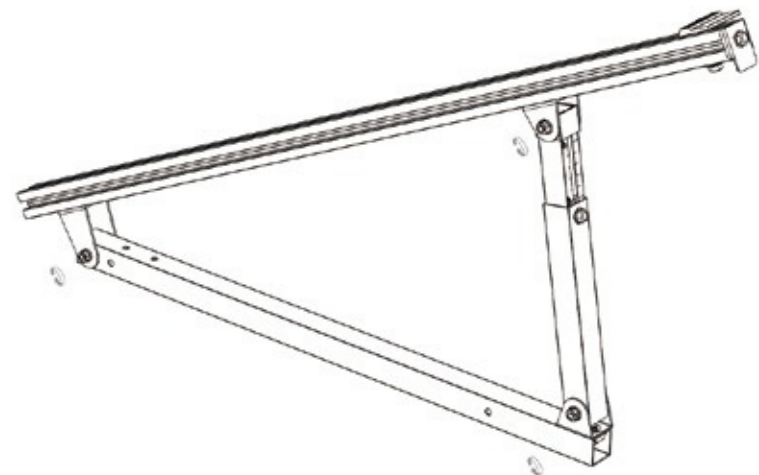
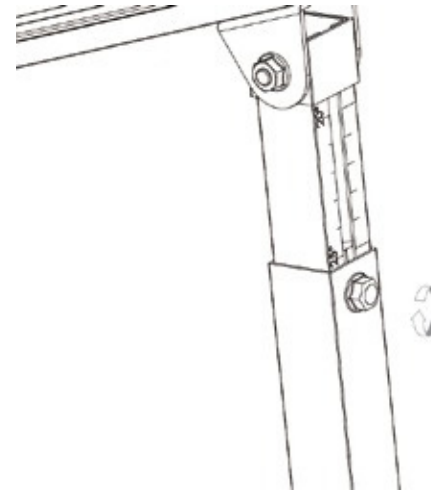

3.4 Repeat steps 3.1-3.3 to assemble another set of tripod
3.4 Wiederholen Sie die Schritte 3.1 bis 3.3 und richten Sie sie am ersten Stativ aus, um die Installation des zweiten Stativ abzuschließen.



3.5 Install the crossbar
3.5 Installieren die Säul

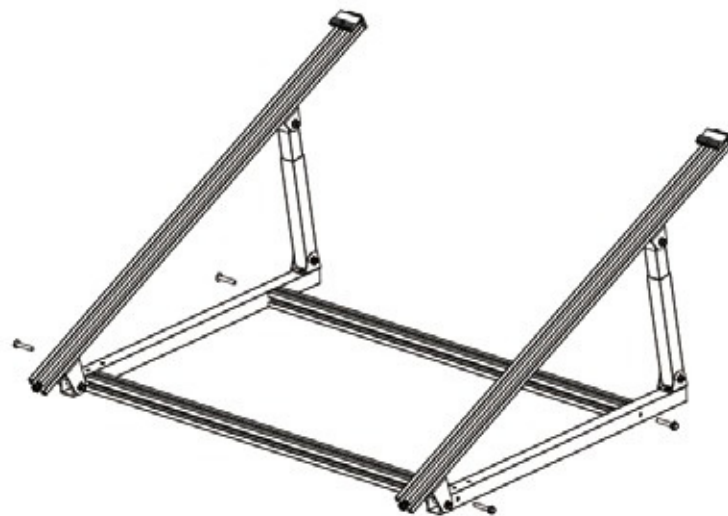
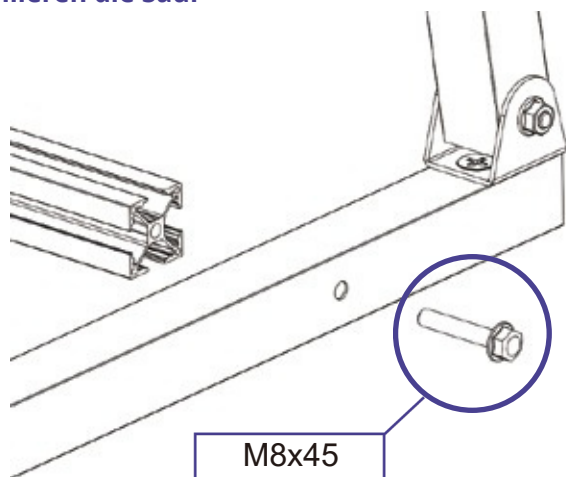

Note 1: The openings on the crossbar need to face up and down, as shown below
Note 1: Die Öffnungen an den Querstangen müssen nach oben und unten zeigen, wie unten gezeigt.

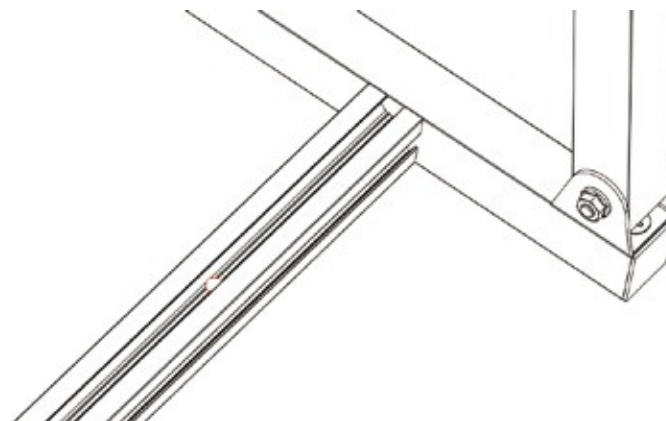

Note 2: If installed on a balcony, this step requires sliding in the balcony fixing block in advance, as shown in the following figure.

Note 2: Bei der Montage auf dem Balkon erfordert dieser Schritt das Einschleiben der Klemmen zur Befestigung des Balkons im Voraus, wie unten gezeigt.

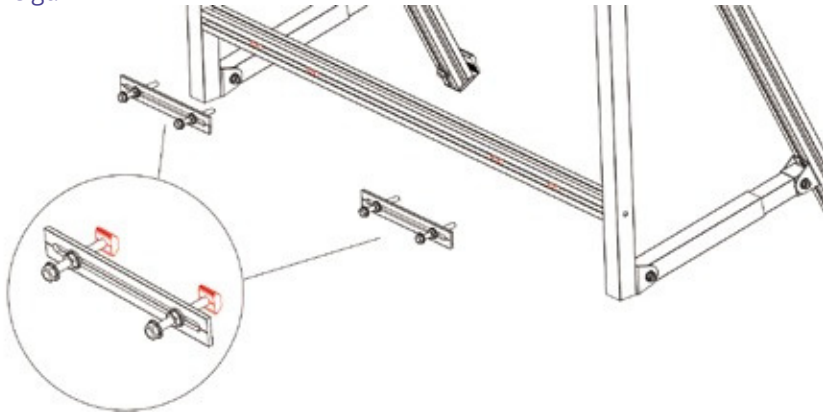

3.6 Install the inverter 3.6 Installieren den Wechselrichter

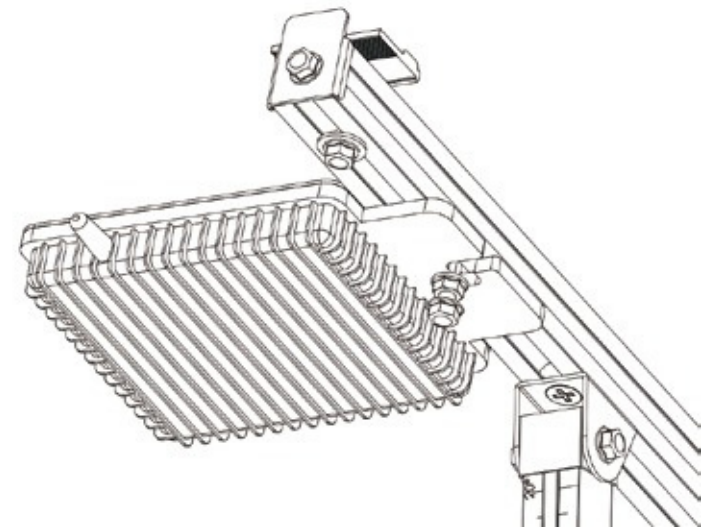
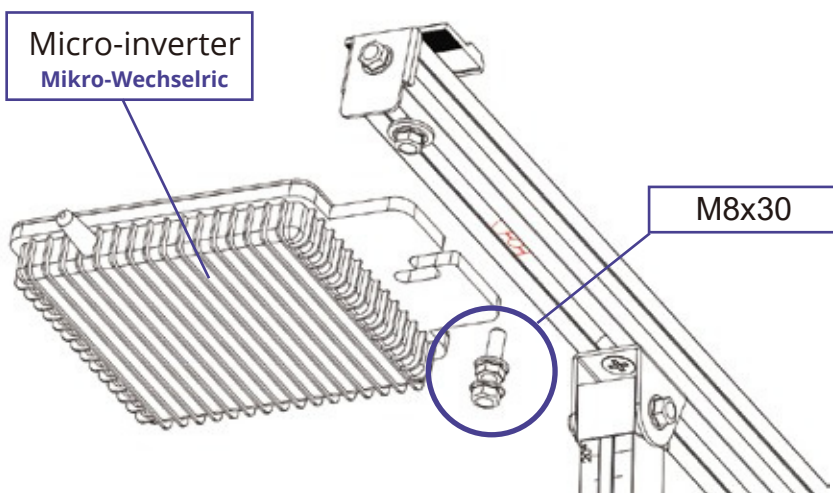

3.7 Install the panel 3.7 Installieren die Solarmodule

3.7.1 Embed the panel into the frame clamps and tighten them
3.7.1 Setzen Sie das Solarmodul in die Rahmenklammern ein und ziehen Sie sie

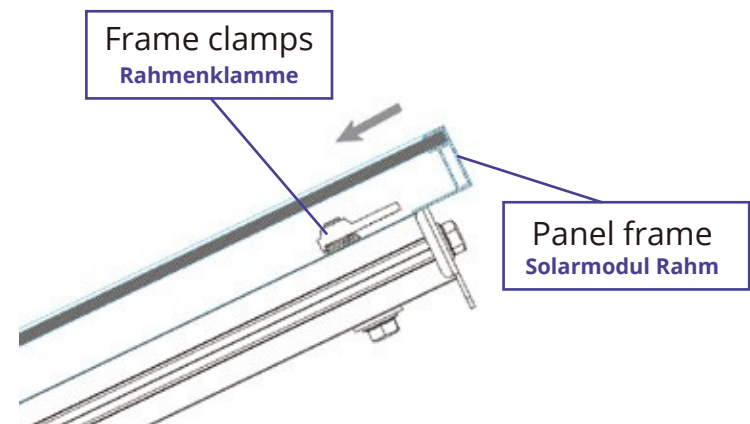

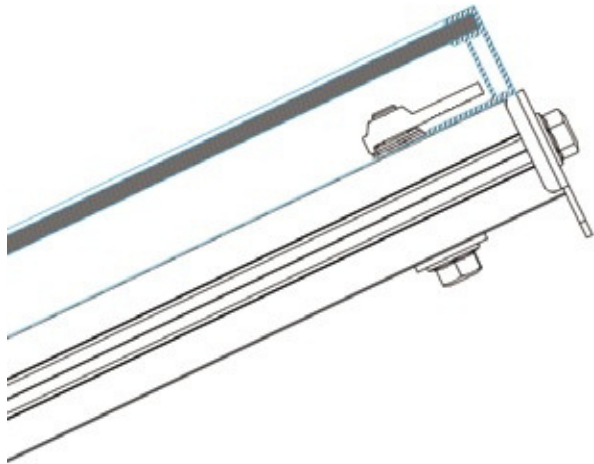

3.7.2 Rotate the cover so that the raised part faces upwards to block the panel, and tighten the bolts slightly.

3.7.2 Drehen Sie die Abdeckung so, dass der erhabene Teil nach oben zeigt, um die Platte zu blockieren, und ziehen Sie die Schrauben leicht an.

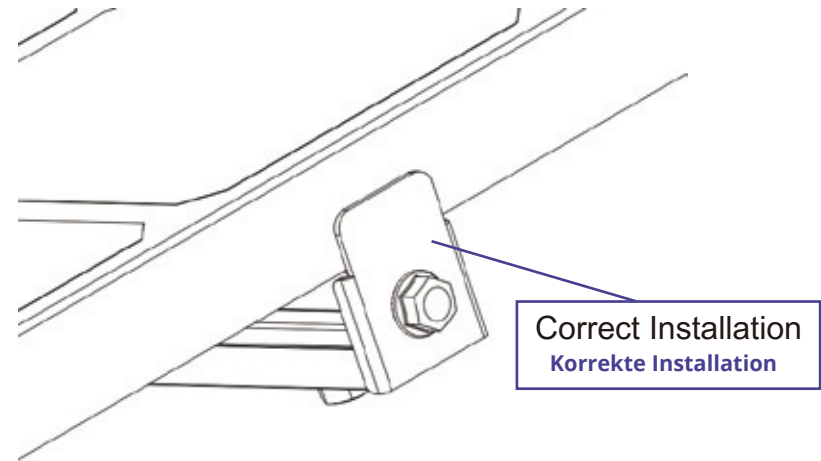
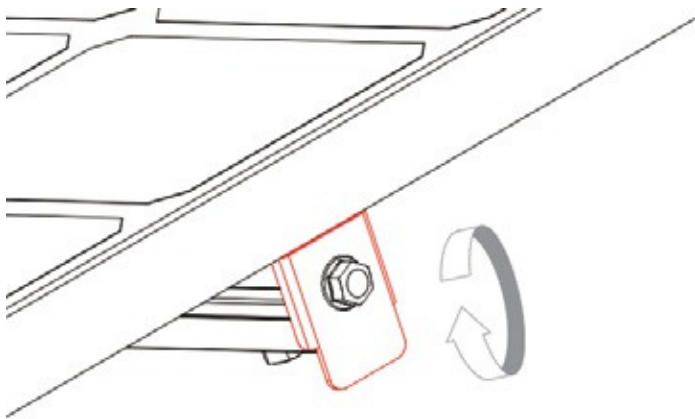

3.7.3 Press the panel with the end clamp and tighten them slightly

3.7.3 Drücken Sie das Solarmodul mit der Endklemme an und ziehen Sie sie leicht an

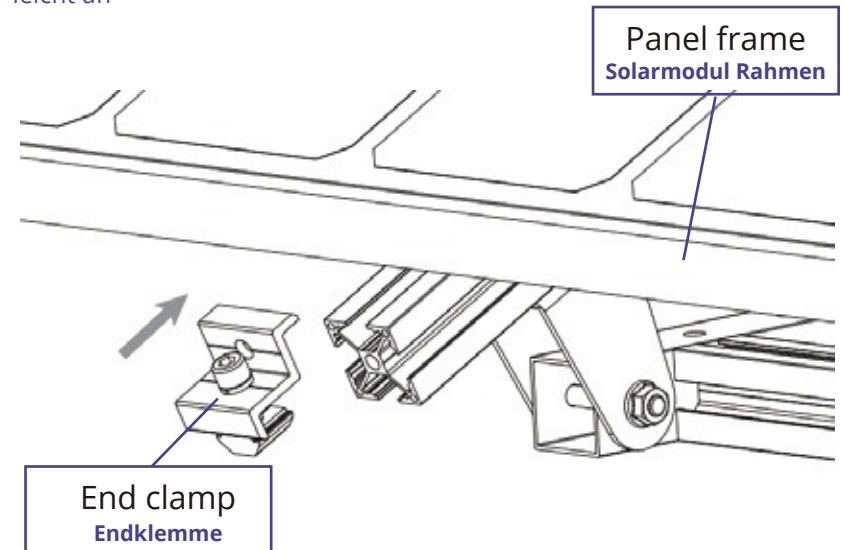

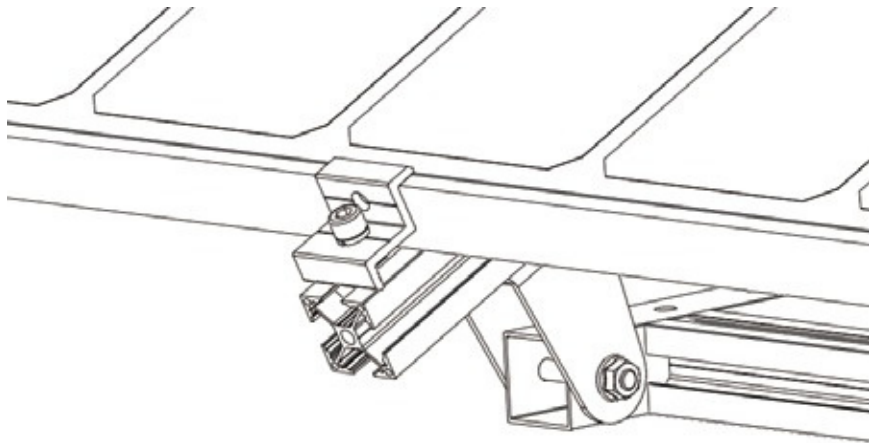

3.7.4 Adjust the panel to align them properly, then tighten the bolts in steps 3.7.1 and 3.7.2, 3.7.3 Installation is complete, below is the sectional view.

3.7.4 DRichten Sie das Solarmodul richtig aus und ziehen Sie dann die Schrauben in den Schritten 3.7.1 und 3.7.2, 3.7.3 fest, Und die Installation ist abgeschlossen.

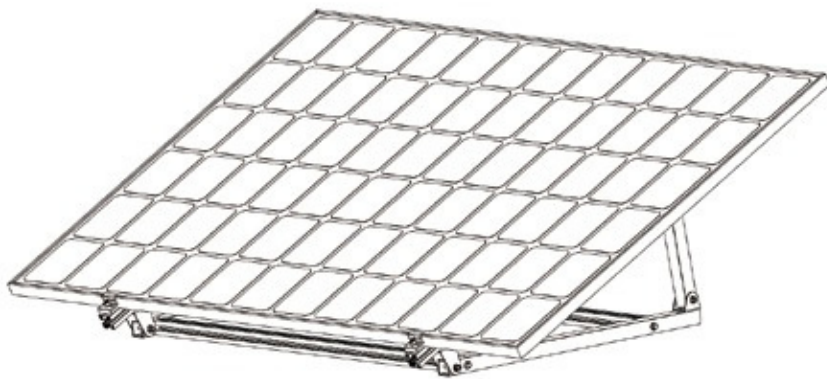

3.8 Install the rubber cap 3.8 Installieren Sie die Gummikappe

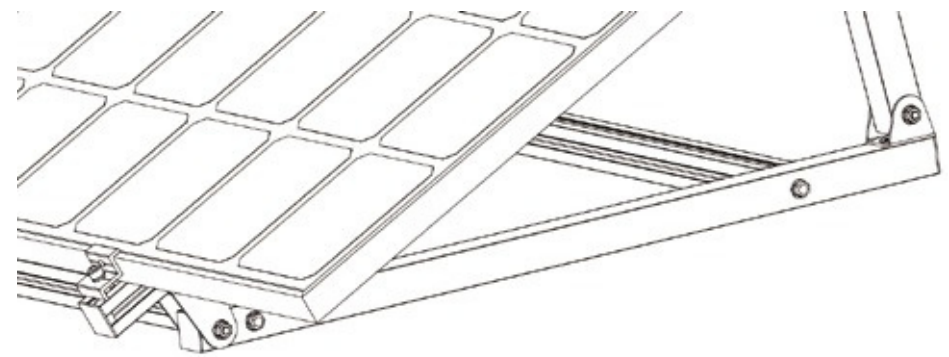
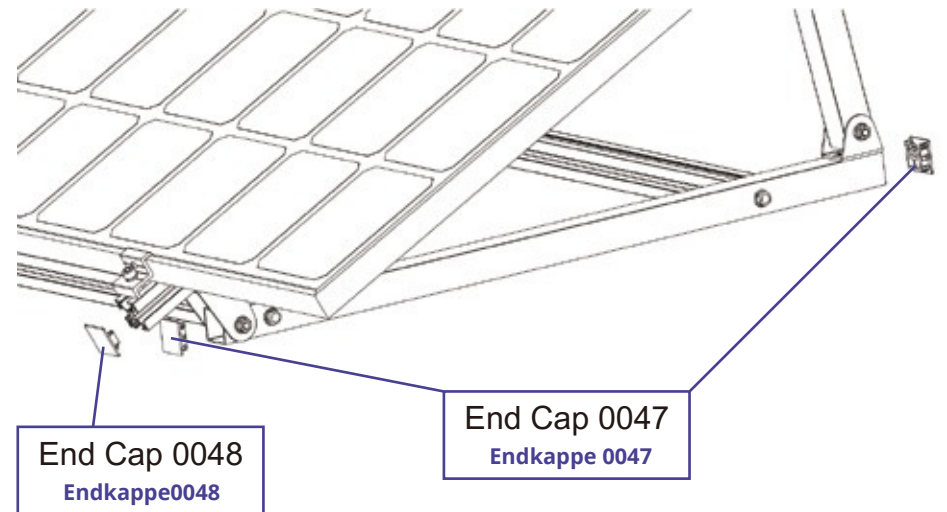

3.9 Place the bracket on the flat ground. The installation is complete
3.9 Stellen Sie die Halterung auf den flachen Boden. Die Installation ist abgeschlossen.

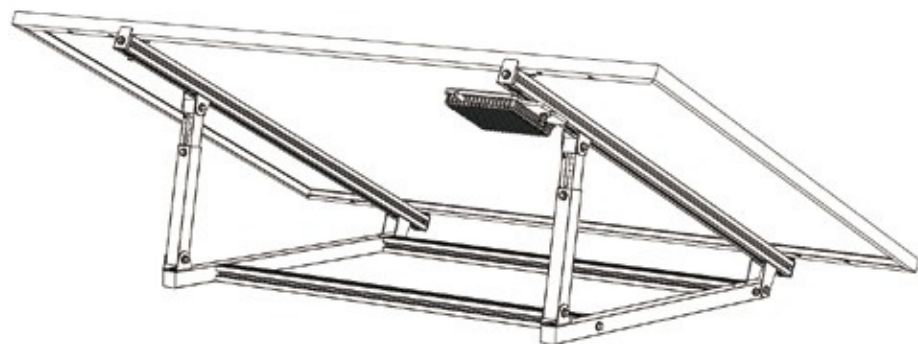
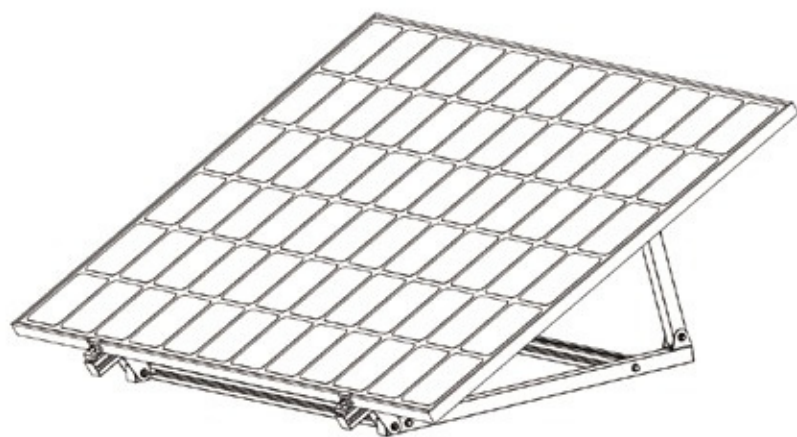

Balcony scene | Szene auf dem Balkon

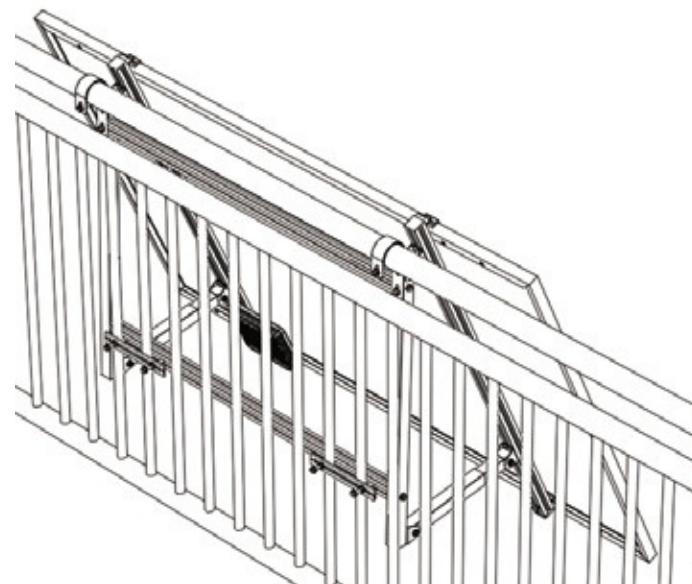
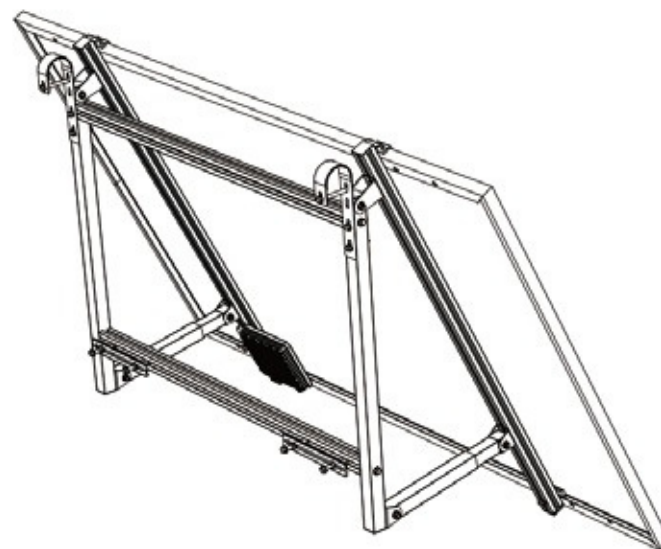

Hook Detail | Detail der Haken

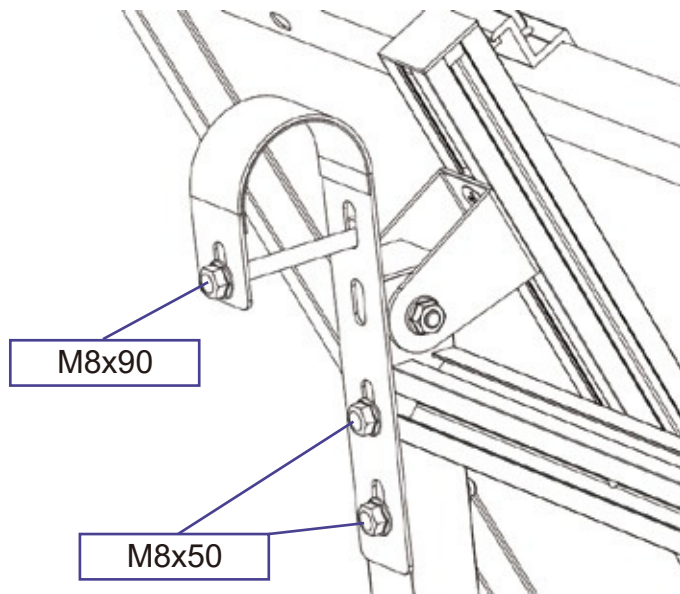

Wall scene | Szene an der Wand

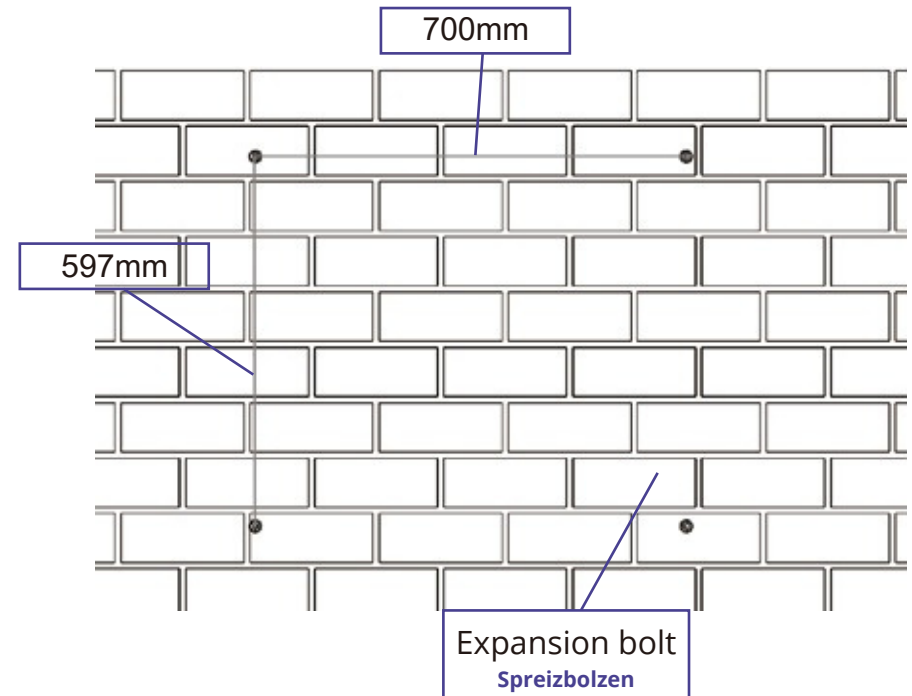

Bottom fastener detail | Detail des unteren Verschlusses

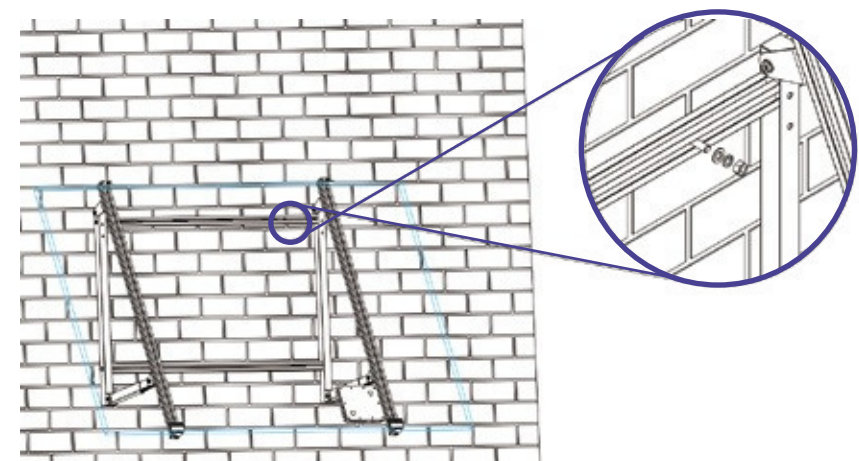
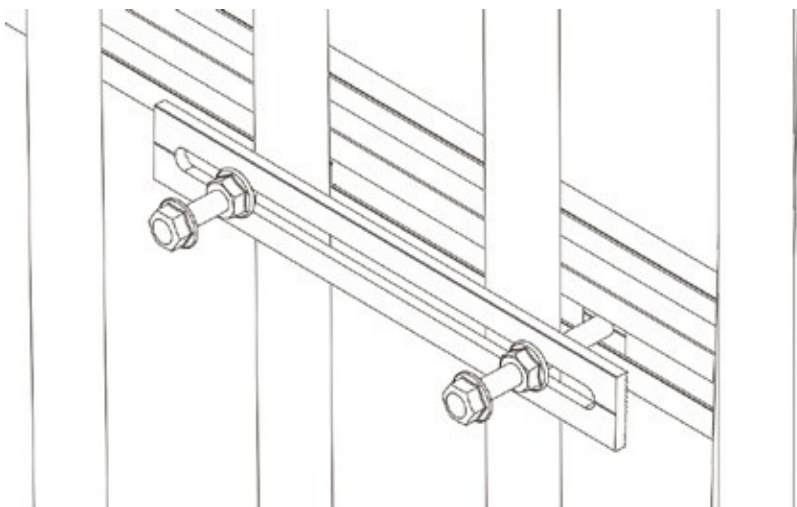

Purchaser/End User/Installer Notice:

Purchasers should confirm whether they are able to install this product and obtain relevant permits in accordance with local laws and regulations, including but not limited to government, community, adjacent property owners, and property rights holders. Purchasers should engage qualified installers, professionals, or self-install only where permitted by law. Purchasers should also ensure that the installation supports the building or its accessories safely and meets installation requirements, and is sufficient to support the product and its photovoltaic power generation system for over 20 years. Purchasers should not install or use this product in environments with corrosive air or water, such as acids or alkalis in the vicinity. Purchasers should fully assess and bear the consequences of product installation and usage and their impact on the surroundings, including but not limited to potential lightning strikes, electrical or magnetic conduction, light reflection/pollution, obstruction of passage, collision with people, snow accumulation and ice shedding, depreciation of buildings, and their consequences. Purchasers are solely responsible for safety during installation, throughout the installation process, and subsequent usage, and/or any impact on third parties. After installing the product, purchasers or their appointed installers should carry out waterproof, leak-proof, and anti-seepage construction at the junction of the product and the building to protect the building supporting the product, and conduct periodic inspections and maintenance in the future (at intervals not exceeding 1 year). Purchasers should be aware that nothing other than the photovoltaic power generation system should be supported on this product, and no additional weight should be placed on the product during installation or subsequent usage, particularly human suspension or leaning. It should not be used for any purpose other than supporting photovoltaic brackets. Purchasers should be aware that nothing other than the photovoltaic power generation battery system should be supported on this product, and no additional weight should be placed on the product during installation or subsequent usage,

particularly human suspension or leaning. It should not be used for any purpose other than supporting photovoltaic brackets. We shall not be liable for any consequences resulting from failure to comply with local legal requirements and/or failure to follow instructions, warnings, etc., during the installation of this product, nor shall we be liable for any losses to the supporting building or any third party resulting from the installation process or subsequent usage, nor shall we be liable for any multiple installations, disassembly and reuse, or second-hand purchases of this product.